



# Codes for Photovoltaic Arc-Fault Protection

**Jay Johnson**

Sandia National Laboratories

Albuquerque, NM

[jjohns2@sandia.gov](mailto:jjohns2@sandia.gov)

14 September, 2012

Solar Power International Conference

Orlando, FL



<http://pvarcfault.sandia.gov>

# PV Arc-Fault Types

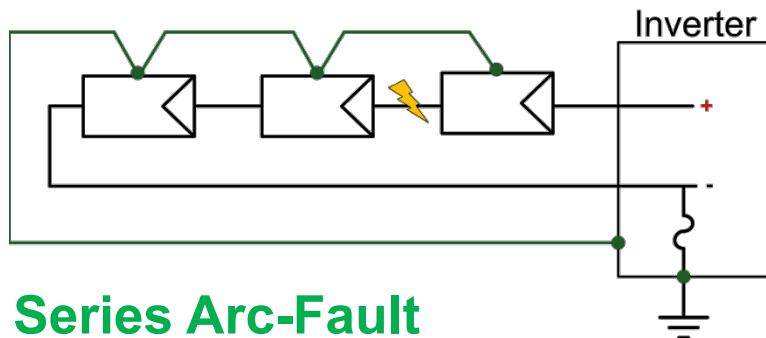

## Series Arc-Fault

**Single** failure in intended conduction path.  
Covered in *NEC* 690.11

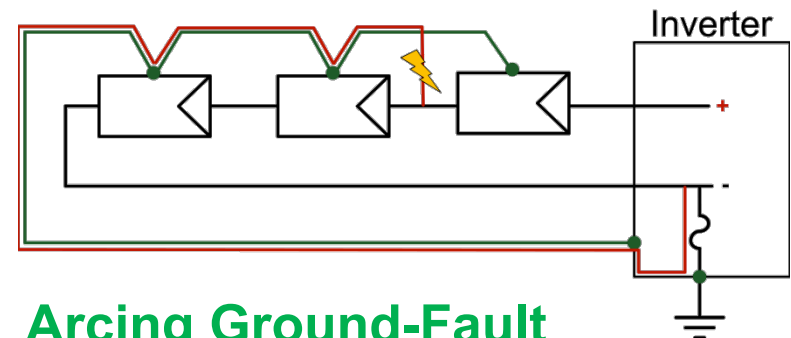

## Arcing Ground-Fault

**Single** failure to equipment ground.  
(Fault current passes through GFPD)  
Covered in *NEC* 690.5

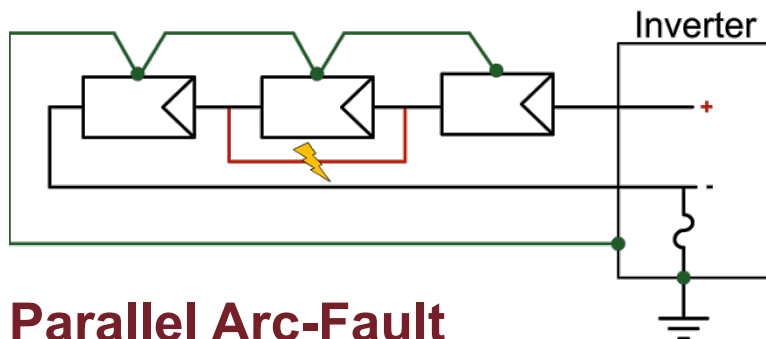

## Parallel Arc-Fault

**Two** failures create new conduction path.  
Not Covered in *NEC*

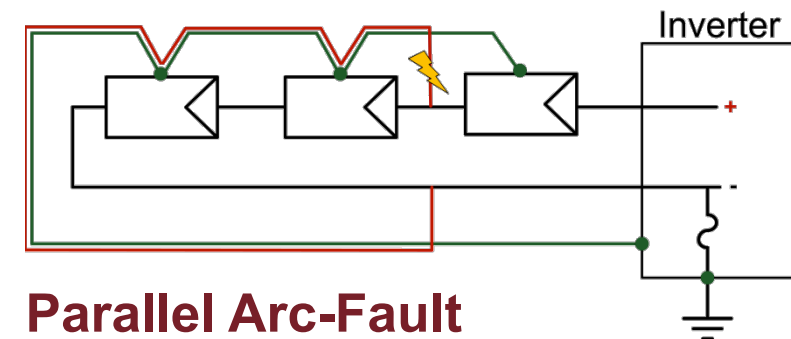

## Parallel Arc-Fault

**Two** failures create new conduction path.  
(Fault current passes through equipment ground but not GFPD)  
Not Covered in *NEC*

GFPD = Ground-Fault Protection Device.



# Arc-Fault Detection and Mitigation

Arc-fault noise propagation (movie)

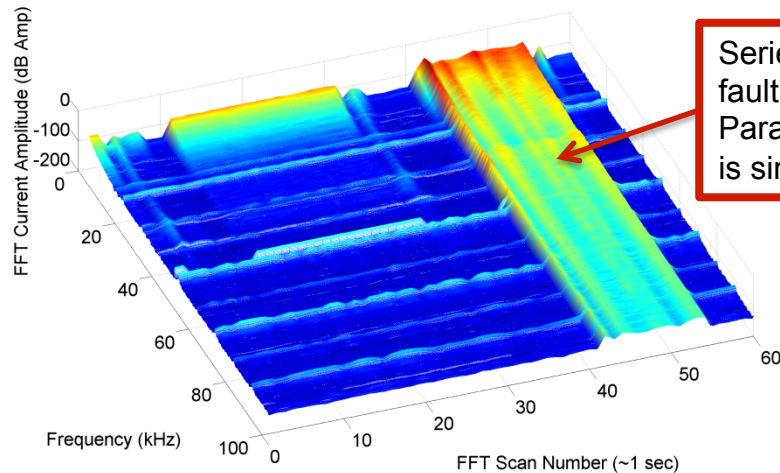
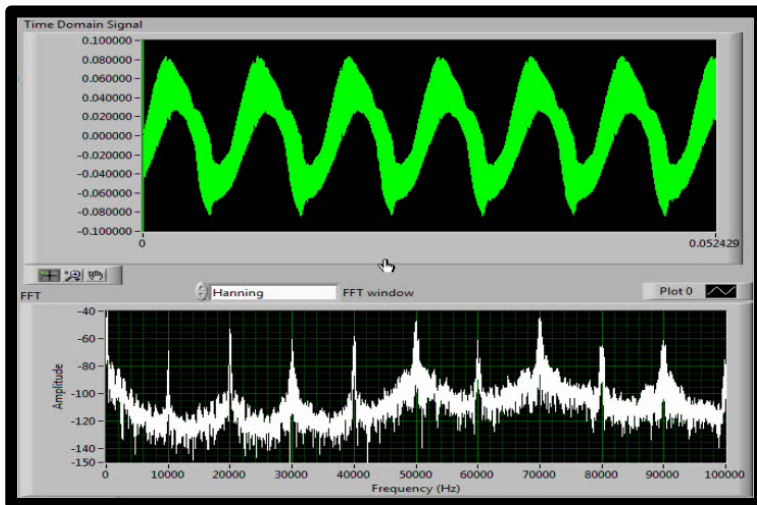

Mitigation (De-energization) Measures

- **Series:** Open the faulted conduction path

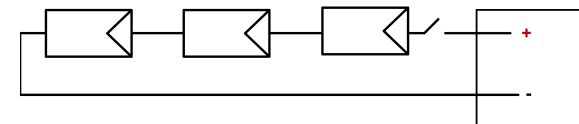

- **Parallel:** No consensus

- Option A: Short the system

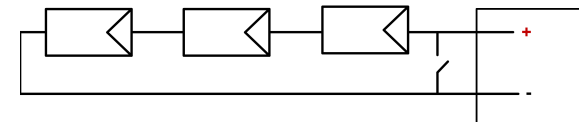

- Option B: Open connections between all modules

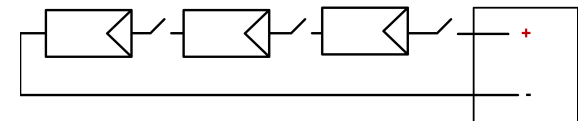

# Summary of 2011 NEC and 2014 Proposals

|                      | 2011 <i>NEC</i> | 2014 <i>NEC</i> Report of Proposals | 2014 <i>NEC</i> 690.11 Task Force Suggestion | Ideal Protection (with Appropriate Mitigation Technology) |
|----------------------|-----------------|-------------------------------------|--|---|
| Series arc-faults    | ✓               | ✓                                   | ✓  | ✓   |
| Parallel arc-faults  |                 | ✓                                   |  | ✓   |
| Rooftop systems      | ✓               | ✓                                   | ✓  | ✓   |
| Ground mount systems |                 | ✓                                   | ✓  | ✓   |



# Parallel Arc-Fault Challenges

- **Parallel arc-fault protection** is needed for 100% safe, fire-free PV systems so **why didn't the NEC 690.11 task subcommittee recommend it** for this code cycle?
- Detection and differentiation of series and parallel arc-faults is **technically feasible** and not the issue.
- The subcommittee hesitation is because the current mitigation options have **limitations!**
  - **Shorting** the array has caused at least one **fire** on a rooftop system.
  - A **shorted** system is also **difficult to repair**: either covering the modules or waiting for night is necessary to de-energize the array to begin work.
  - **Opening connections** between each module **does not eliminate parallel arc-faults** in the modules, junction boxes, or module leads.
  - **Opening** between each module adds **communication and control complexity**.
- **Mitigation methodologies need additional testing** and **parallel arc-faults are rare\***, so it will likely be 2017 before there are requirements for parallel arc-fault protection in PV systems.
- **Stay tuned for the NEC Code Making Panel's decision!**

\*Based on <http://www.pv-brandsicherheit.de/> results and SEIA data.